

SERVICE

BULLETIN (REVISION B)

DATE:	May 01, 2000	# of Pages: 4
REFERENCE:	SERVICE BULLETIN # SPSB: 03032000 – Revision B	
SUBJECT:	MAIN CLOSING LOOP RETAINER – Grommet Protection	
STATUS:	MANDATORY for Javelin's manufactured prior to September 1993, RECOMMENDED for Javelin's manufactured September 1993 up to and including March 2000.	

IDENTIFICATION:

Javelin Harness/Container Assemblies: Javelins Manufactured Prior to and including March 2000.

BACKGROUND:

Small diameter main canopy suspension lines (similar to Microline 550 and Vectran 500) can get caught around the grommet in the main Closing Loop Retainer and could result in a serious horseshoe malfunction with a suspension or steering line caught in the container after deployment.

SERVICE BULLETIN REVISION A: Rescinded April 19, 2000.

SERVICE BULLETIN REVISION B:

Before Next Jump - The **mandated** field repair for **Javelins manufactured prior to September 1993**, (as addressed in Service Bulletin # SPSB 03032000) must be done by a suitably qualified rigger.

At Next Reserve Repack - The **mandatory** modification for the Closing Loop Retainer affecting **Javelin's manufactured prior to September 1993**, must be done by a suitably qualified rigger. See attached instructions.

MINIMUM TOOLS REQUIRED:

Sewing machine (capable of both straight and zig-zag stitching), Unpicker, Scissors, Nylon E-Thread, Marking Pencil.

COMPLIANCE:

Before Next Jump:

Service Bulletin # SPSB 03032000 **Mandatory for Javelins manufactured prior to September 1993.**

At the next reserve repack:

- | | |
|--------------------------------------|---|
| 1. # SPSB 03032000 Revision B | Mandatory for Javelins manufactured prior to September 1993. |
| 2. # SPSB 03032000 Revision B | Recommended for Javelins manufactured September 1993 up to and including March 2000. |

Note compliance with this Service Bulletin on Packing Data Card.

AUTHORITY:

Derek Thomas, President
Sun Path Products, Inc.
4439 Skydive Lane, Zephyrhills, FL 33540, USA.
Telephone: (813) 782-9242, Fax: (813) 788-3057
E-mail: info@sunpath.com

DISTRIBUTION:

- | | |
|---|--|
| 1. Sun Path Products, Inc. Website www.sunpath.com | 2. All Sun Path Products, Inc. Dealers. |
| 3. PIA Technical and Rigging Committee. | 4. IPC Technical Committee |
| 5. FAA ORL MIDO | 6. FAA Engineering Atlanta |
| 7. All Parachuting Publications. | 8. National Aero Clubs, Parachuting Section. |
| 9. Military Parachute Organizations. | |

Service Bulletin SPSB # 03032000 Revision B

1. Unpick and remove bartacks carefully. [Fig 1].

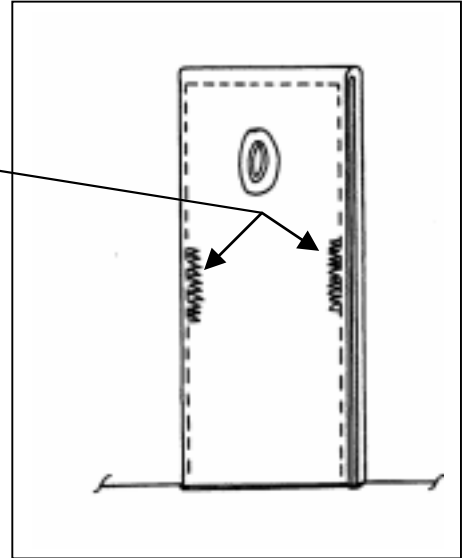

FIGURE 1

2. You should have a continuous loop of Type 12. [Fig 2].
3. Some older rigs had a short cover behind the grommet [Fig 3]. Follow the instructions below ignoring the references to the continuous loop in the diagrams. Your end result will be the covering of the grommet and final bartacking of the short cover in place. [Fig 6].

Mark closing loop retainer at midpoint of removed bartacks with marker pencil.

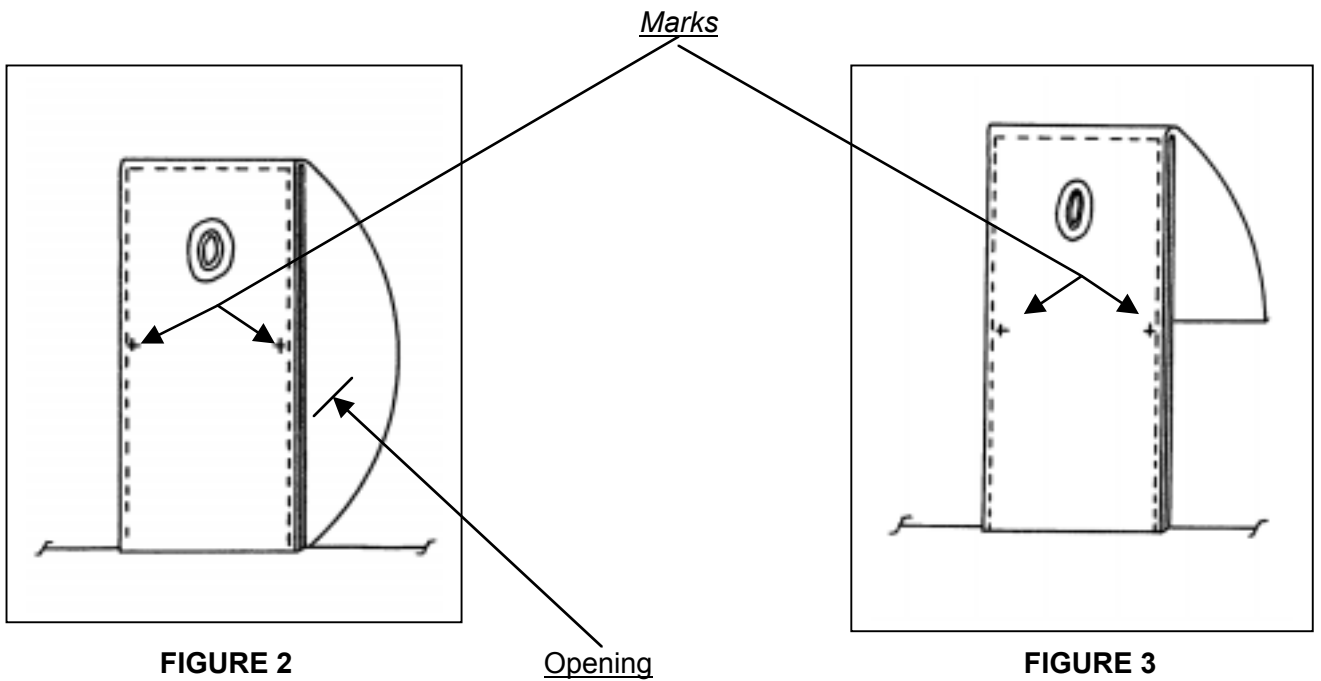

FIGURE 2

Opening

FIGURE 3

- Cut Type 12 webbing at 6" (165mm) for short closing loop retainers (most Javelins) or, 10" (260mm) for long closing loop retainers found on J6N, J7N, J10 and J12's.

Line up hot-knifed edge of Type 12 webbing at marks as marked in Fig 2 & 3.

Lay Type 12 towards grommet and fold it so that the fold lines up with the top of the grommet.

Mark the top layer of Type 12 directly above the two marks as marked in Fig 2 & 3.

Using a straight stitch machine sew along the edge of the tape from a mid-bartack mark up to and one stitch over the fold and return to the mark.

Sew only to the layers of Type 12 that the grommet is set through. Do **NOT** sew through the back part of the closing loop retainer. (Continuous loop or short cover).

Repeat on other side [Fig 4].

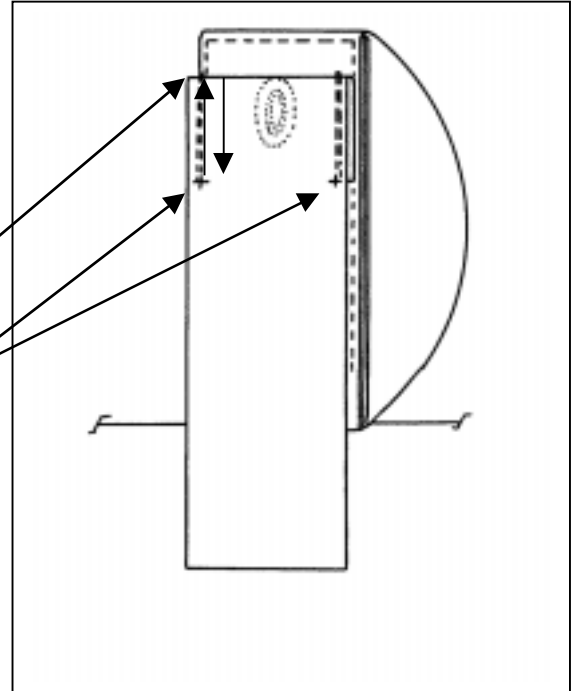

FIGURE 4

- Lay closing loop retainer flat and fold unsewn piece so that the fold is as close to the reserve container as possible.

Sew around three sides from mark to mark as made in Fig 4.

Be careful not to sew closed the opening for the closing loop. [Fig 5].

Fold

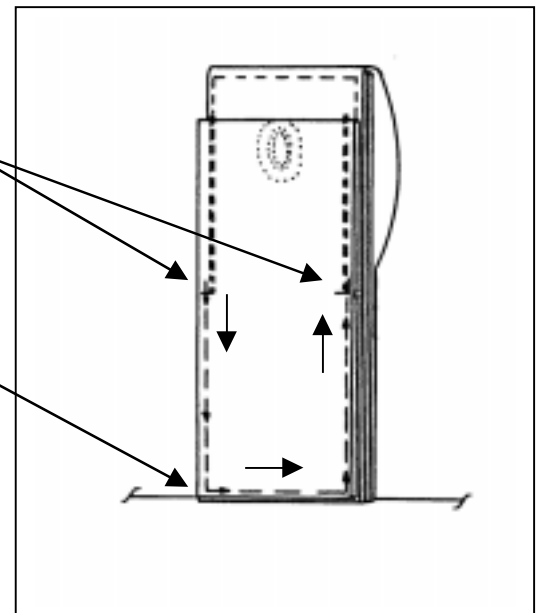

FIGURE 5

6. Replace bartacks or zig-zag new locking stitches in same place as the ones taken out. [Fig 6].

NOTE: The short cover must be secured in place with the bartacks.

Bartacks

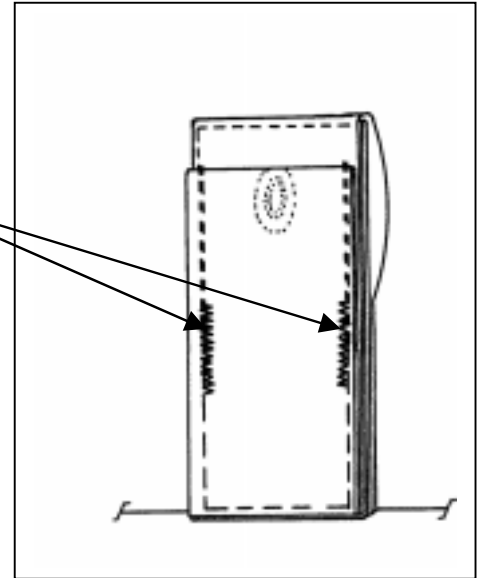

FIGURE 6

Trim threads and update Packing Data Card with Service Bulletin Compliance.

Service Bulletin SPSB #03032000 Revision A Update.

If you have already complied with Service Bulletin # SPSB 03032000 Revision A do as follows:-

Unpick the 4 x securing stitch rows along each side of the modified main closing loop retainer.

Follow Steps 2 through 6 above.